

Typical Features

- ◆ Wide input voltage range (4:1), output power 50W
- ◆ Efficiency up to 89%(Typ.)
- ◆ Standby power consumption 3W(Typ.)
- ◆ Output fast start-up
- ◆ Continuous short circuit protection, Self-recovery
- ◆ Input under voltage, output over voltage, short circuit, over current protections
- ◆ Isolation voltage 3000VDC/1500VAC
- ◆ Operating temperature from -40°C to +85°C
- ◆ Good EMC performance
- ◆ Standard pin-out alignment



Application Field

FD50-110SXXB3C3(-XXX) Series ---The FD50-110SXXB3C3(-XXX) series is a 40W DC-DC converter featuring a 4:1 wide input voltage range, ultra-fast startup, and isolated regulated single output. Available in DIP, Chassis, and DIN-Rail packages, it provides 3000VDC/1500VAC isolation. The series includes comprehensive protection against input under-voltage, output over-current, short-circuit, and output over-voltage. These modules are widely used in 72V, 96V, and 110V systems for industrial control, electric power, communications, locomotives, industrial robots, and railway electronics. For harsh electromagnetic environments, please refer to the recommended EMC application circuits.

Selection Guide

Certificate	Part No.	Input Voltage Range (VDC)		Output Voltage/ Current (Vo/Io)		Input current (mA) Typ. @Nominal Voltage		Max Capacitive Load μF	Ripple & Noise (mVp-p)		Efficiency @full load (%)	
		Nom.	Range	Vo (VDC)	Io(mA) Max/Min	Full Load	No Load		Typ.	Max	Min	Typ.
CE	FD50-110S3V3B3(C)3	110	40 - 160	3.3	10 000	345	25	10000	50	100	83	85
	FD50-110S05B3(C)3			5	10 000	525	25	8000	50	100	84	86
	FD50-110S12B3(C)3			12	4167	525	2	3300	150	200	86	88
	FD50-110S15B3(C)3			15	3333	525	2	1200	150	200	86	88
	FD50-110S24B3(C)3			24	2083	525	2	680	150	200	87	89
	FD50-110S48B3(C)3			48	1042	525	2	470	150	200	87	89

Note 1: "C" indicates Remote Control pin; "N" indicates No Remote Control. Suffix "-H" denotes with heat sink; "-T(H)" denotes Chassis mounting (with heat sink); "-TS(H)" denotes DIN-Rail mounting (with heat sink, 35mm rail).

Note 2: Max. Capacitive Load refers to the maximum allowable output capacitance during full-load startup. Exceeding this value may prevent the power supply from starting.

Note 3: To reduce no-load power consumption and improve light-load efficiency, the IC operates in frequency-hopping mode under no-load or light-load conditions. A minimum 5% load or an external high-frequency electrolytic capacitor ($\geq 470 \mu F$) is required; otherwise, output ripple may increase.

Note 4: This list is for reference only. For products or specifications not listed, please contact our Sales Department.

Input Specifications

Items	Test Conditions	Min.	Typ.	Max.	Unit
Stand-by Power Consumption	Full input voltage range	/	3	/	W
Under-Voltage Protection	110V Nominal Input Series	32	/	40	VDC
Input inrush voltage (1sec.max)	110V Nominal Input Series	-0.7	/	160	VDC
Turn on delay	/	/	10	/	ms
Hot plug	/	N/A			
Input Filter	/	π filter			
Reflected ripple current	110V Nominal Input Series	100mA (Typ.)			
Ctrl (Remote Control)	Module ON	Floating or High Level (3.5 - 12VDC)			
	Module OFF	Connect to -Vin or low level (0-1.2VDC)			
	Off-state Input Current	1mA (Typ.)			

*Note: The voltage of Ctrl is relative to the input -Vin.

Output Specifications

Items	Test Conditions	Min.	Typ.	Max.	Unit	
Output Voltage Accuracy	Full input voltage range	/	± 1	± 2	%	
Voltage Regulation	Full input voltage range, full load	/	± 0.5	± 1	%	
Load Regulation	10%-100% load	/	± 0.5	± 1	%	
Ripple & Noise	5%-100% load, 20MHz bandwidth	3.3V/5V output	/	50	100	mVp-p
		Others	/	150	200	
Dynamic Recovery Time	25% rated load step, nominal input voltage	/	/	300	500	μS
Dynamic Response Deviation		3.3V/5V output	/	± 5	± 8	%
		Others	/	± 3	± 5	
Output voltage TRIM	Full input voltage range	/	/	10	%Vo	
Over voltage protection		110	150	190	%Vo	
Over current protection		120	150	200	%Io	
Short Circuit Protection		Hiccup, continuous, self-recovery				

Note: Ripple & noise $\leq 5\%V_o$ at 0-5% load, it is tested by the twisted pair method according to the following test instruction.

General Specifications					
Items	Test Conditions	Min.	Typ.	Max.	Unit
Switching Frequency	Operating Mode (PWM)	/	300	/	KHz
Operating Temperature	Refer to the Temperature Derating Graph	-40	/	+85	°C
Storage Temperature	/	-55	/	+125	
Max case temperature	Within the temperature derating range	/	/	+105	°C
Pin Soldering Temperature	1.5mm from the case, 10 seconds	/	/	300	°C
Relative Humidity	No condensing	5	/	95	%RH
Isolation Voltage	I/P-O/P, test 1min, leakage current <0.5mA	3000	/	/	VDC
	I/P-O/P, test 1min, leakage current <5mA	1500	/	/	VAC
Isolation Capacitance	/	/	2000	/	pF
MTBF	MIL-HDBK-217F@25°C	1000	/	/	K hours
Cooling Method	Nature air				
Case Material	Aluminum				
Weights/Dimensions	Part No.	Weight (Typ.)	Dimensions L x W x H		
	FD50-110SXXB3C3	30g	50.80X25.40X13.00 mm	2.00X1.00X0.511 inch	
	FD50-110SXXB3C3-H	42g	50.80X25.40X23.00 mm	2.00X1.00X0.906 inch	
	FD50-110SXXB3C3-T	51g	76.00X31.50X22.30 mm	2.99X1.24X0.877 inch	
	FD50-110SXXB3C3-TH	63g	76.00X31.50X32.50 mm	2.99X1.24X1.279 inch	
	FD50-110SXXB3C3-TS	71g	76.00X31.50X27.00 mm	2.99X1.24X1.063 inch	
	FD50-110XXSXXB3C3-TSH	83g	76.00X31.50X36.50mm	2.99X1.24X1.437 inch	

EMC Performance				
Total Item	Sub Item	Test Standard	Performance/Class	
EMC	EMI	CE	CISPR32/EN55032	CLASS A (With the Recommended EMC Circuit)
	EMS	RS	IEC/EN61000-4-3	10V/m Perf.Criteria A (With the Recommended EMC Circuit)
		CS	IEC/EN61000-4-6	3Vr.m.s Perf.Criteria A (With the Recommended EMC Circuit)
		ESD	IEC/EN61000-4-2	Contact ±4KV Perf.Criteria B
		EFT	IEC/EN61000-4-4	±2KV Perf.Criteria B (With the Recommended EMC Circuit)

Ripple & Noise Test Instruction (Twisted Pair Method, 20MHZ bandwidth)

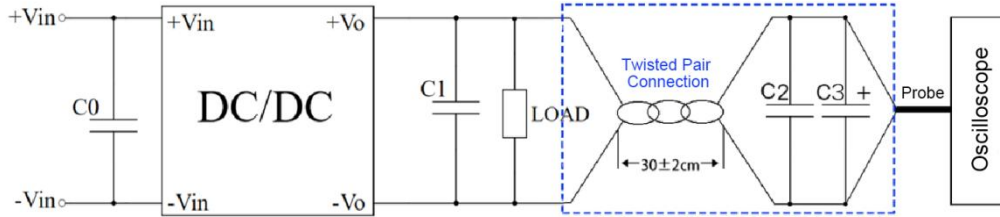

- 1) The Ripple & noise test needs 12# twisted pair cables, an oscilloscope which should be set at the Sample Mode, bandwidth 20MHz. 100M bandwidth probe with cap and ground removed. C2(0.1μF) polypropylene capacitor and C3(10μF) high-frequency low-resistance electrolytic capacitor are connected in parallel with the probes and one side of the twisted pair. C0 & C1 refer to the application circuit recommended.
- 2) The power supply output connects to the load by the cables. The other side of the twisted pair (length 30cm± 2cm) should be connected in parallel with the load, the polarity of the output and the oscilloscope probe should not be reverse. The test can be start after input power on.
- 3) It is recommended to connect a ≥5% load or a high-frequency resistance E-cap(≥470μF) load at output to avoid the output ripple increasing.

Product Characteristics Curves

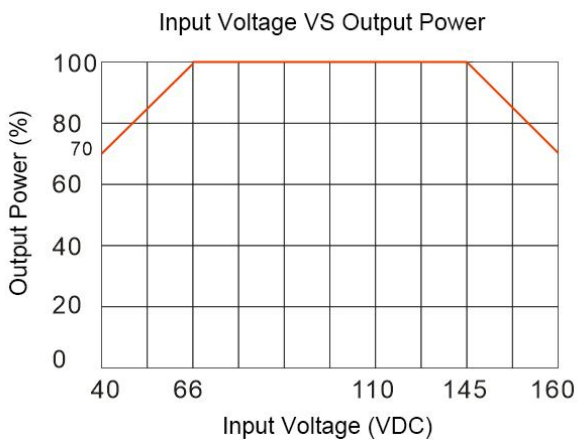
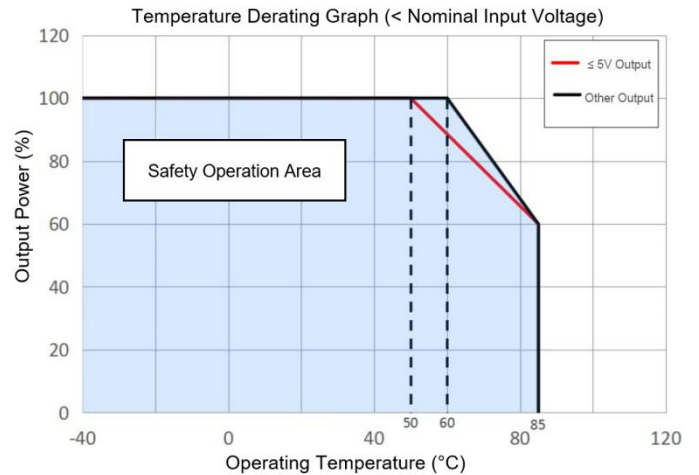
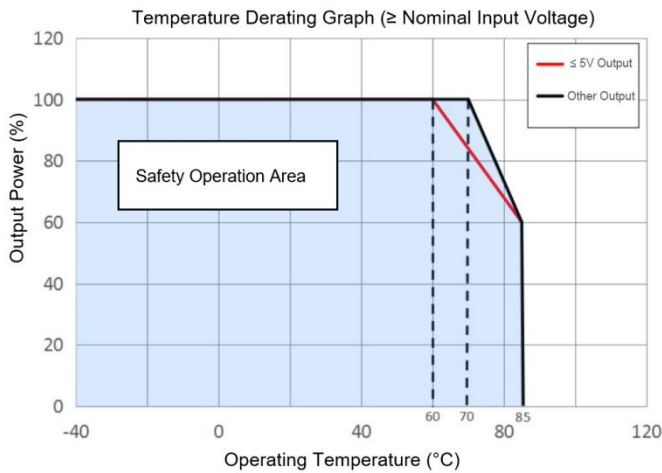

Recommended Circuits for Application

1. All this series of converters will be tested according to this circuit diagram before shipping. Increasing the capacity of C0 or C1 can decrease the output ripple, but the output capacitance must be less than the maximum capacitive load.

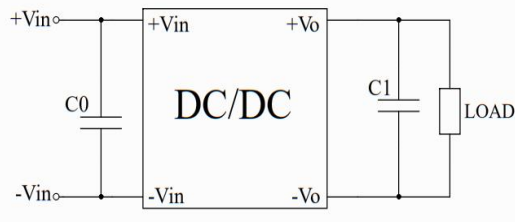

Components	Parameters
C0	47-100μF/200V
C1	470μF/50V

2. Input Reflected Ripple Current Test Circuit

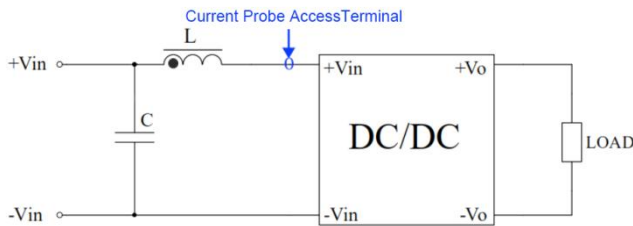

Components	Parameters
C	220μF/200V
L	4.7uH/15A

3. Recommended EMC circuit diagram

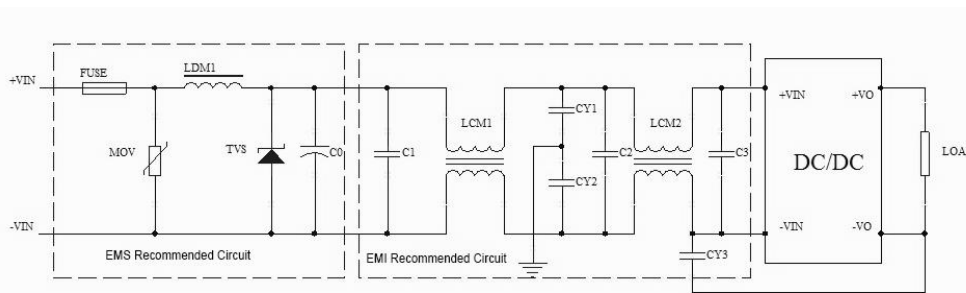

Components	110V Nom. Input
FUSE	Per Load Req.
MOV	14D201K
LDM1	56uH
TVS	SMCJ170A
C0	560μF/200V
C1,C2,C3	4.7μF/200V
LCM1	15mH
LCM2	56uH
CY1,CY2,CY3	1nF/3KV

4. Trim and calculation of Trim resistance

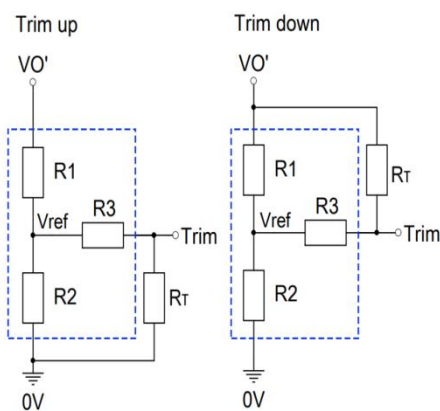

Calculation formula of Trim resistance:

$$\begin{aligned} \text{up: } R_T &= \frac{\alpha R_2}{R_2 - \alpha} - R_3 & \alpha &= \frac{V_{ref}}{V_o' - V_{ref}} \cdot R_1 \\ \text{down: } R_T &= \frac{\alpha R_1}{R_1 - \alpha} - R_3 & \alpha &= \frac{V_o' - V_{ref}}{V_{ref}} \cdot R_2 \end{aligned}$$

RT is the Trim resistor, α is a custom parameter, and Vo' is the actual voltage of Trim up or Trim down.

Output Voltage	Trim internal circuit parameters			
Vout (DC)	R1(KΩ)	R2(KΩ)	R3(KΩ)	Vref (V)
3.3	24	14.53	68	1.25
5	24	24	68	2.5
12	18	4.7	30	2.5
15	24	4.78	30	2.5
24	25.5	2.955	18	2.5

Note: Trim up & down circuits, the components in the dotted area are inside of the converter.

B3 Package Dimension (Without heat-sink)

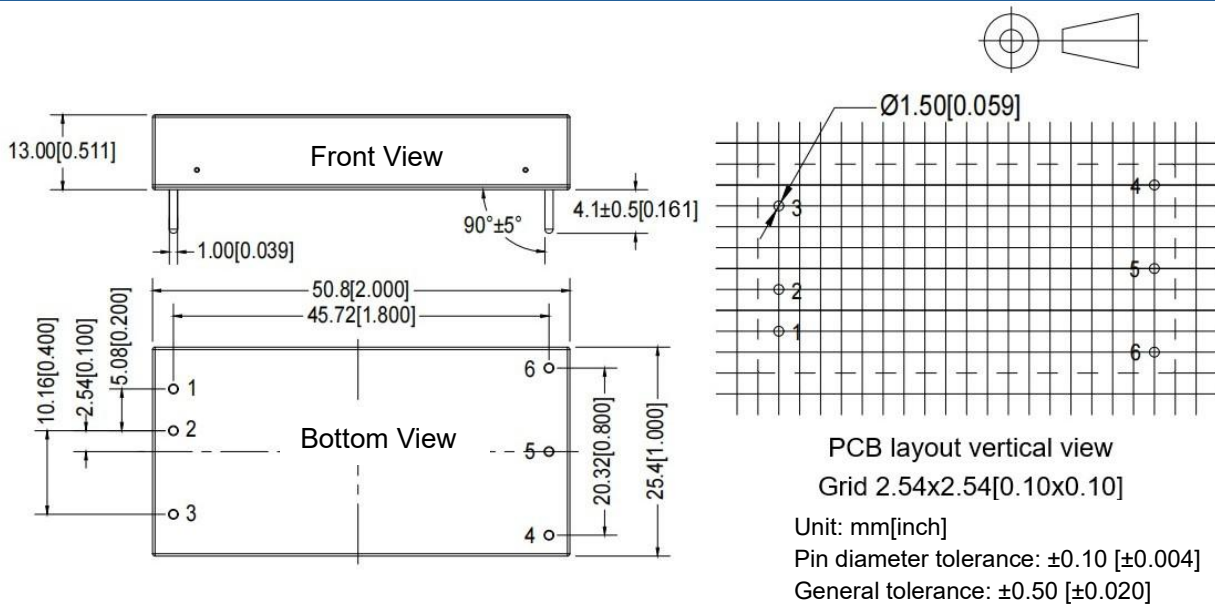

Pin No.	1	2	3	4	5	6
FD50-110SXXB3C3	+Vin	-Vin	Ctrl	Trim	-Vout	+Vout

B3-H Package Dimension (With heat-sink)

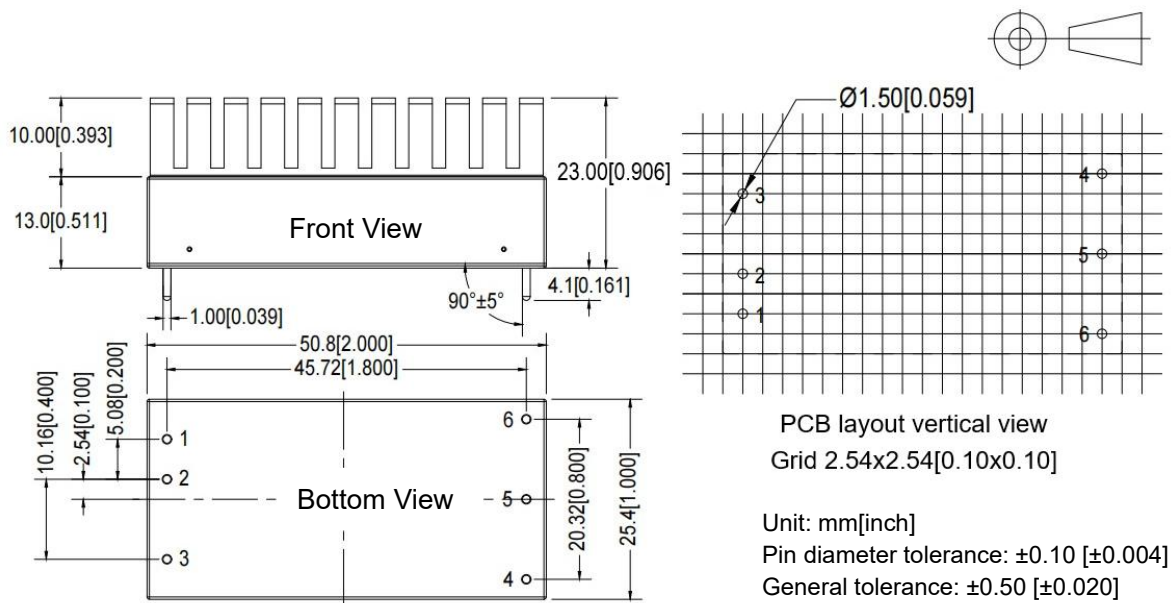

Pin No.	1	2	3	4	5	6
FD50-110SXXB3C3	+Vin	-Vin	Ctrl	Trim	-Vout	+Vout

B3-T Packing Dimension (Without heat-sink)

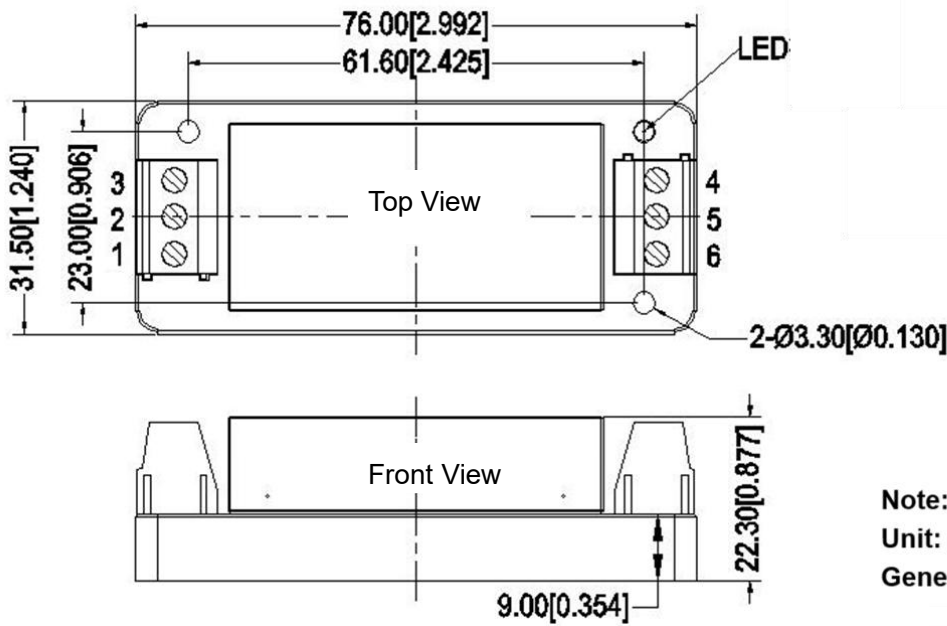

Note:
 Unit: mm[inch]
 General tolerance: $\pm 1.0[\pm 0.04]$

Terminal No.	1	2	3	4	5	6
FD50-110SXXB3C3	+Vin	-Vin	Ctrl	Trim	-Vout	+Vout

B3-TH Package Dimension (With heat-sink)

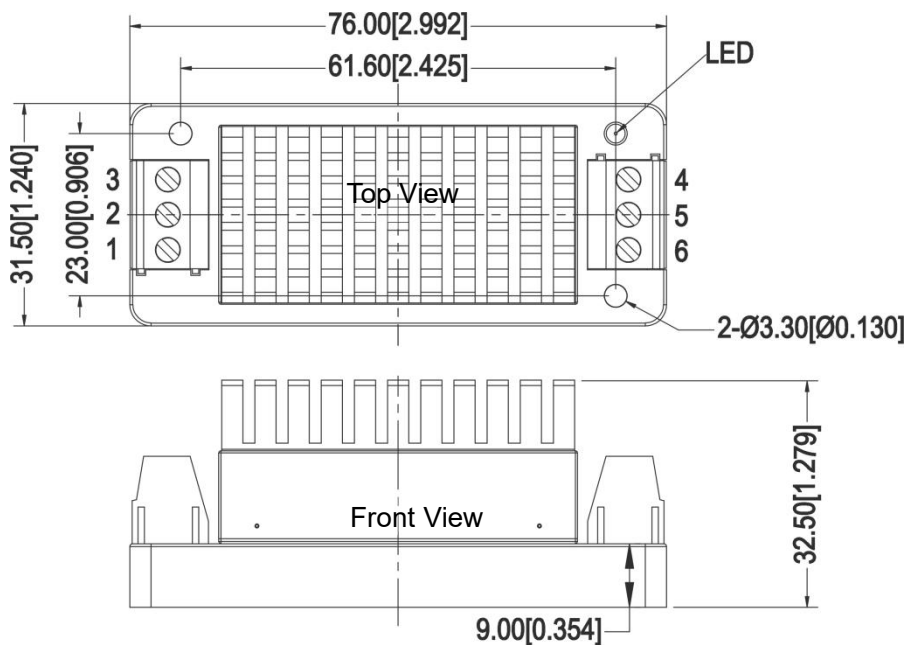

Note:
 Unit: mm[inch]
 General tolerance: $\pm 1.0[\pm 0.04]$

Terminal No.	1	2	3	4	5	6
FD50-110SXXB3C3	+Vin	-Vin	Ctrl	Trim	-Vout	+Vout

B3-TS Package Dimension (Without heat-sink)

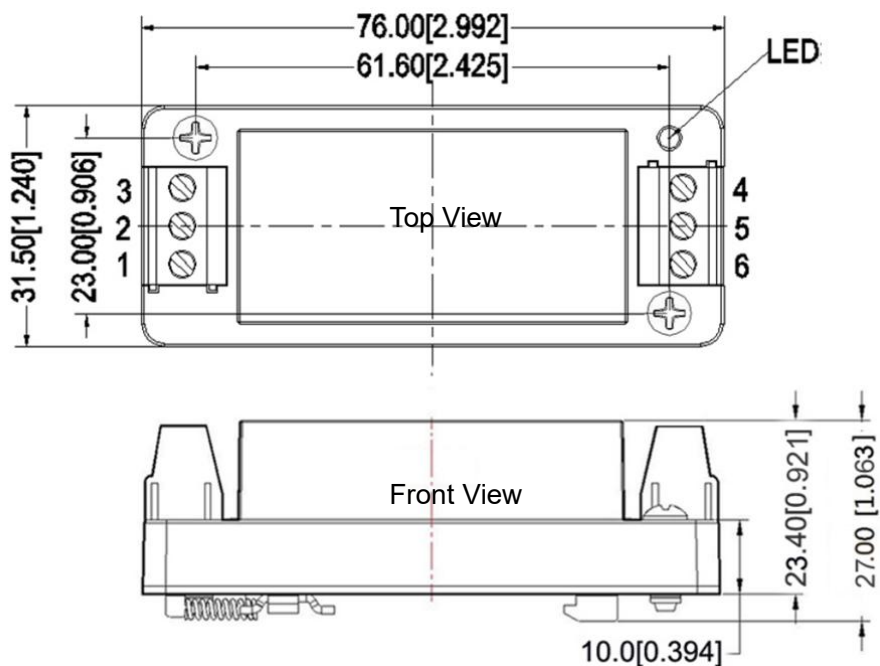

Note:
 Unit: mm[inch]
 General tolerance: $\pm 1.0[\pm 0.04]$

Terminal No.	1	2	3	4	5	6
FD50-110SXXB3C3	+Vin	-Vin	Ctrl	Trim	-Vout	+Vout

B3-TSH Package Dimension (With heat-sink)

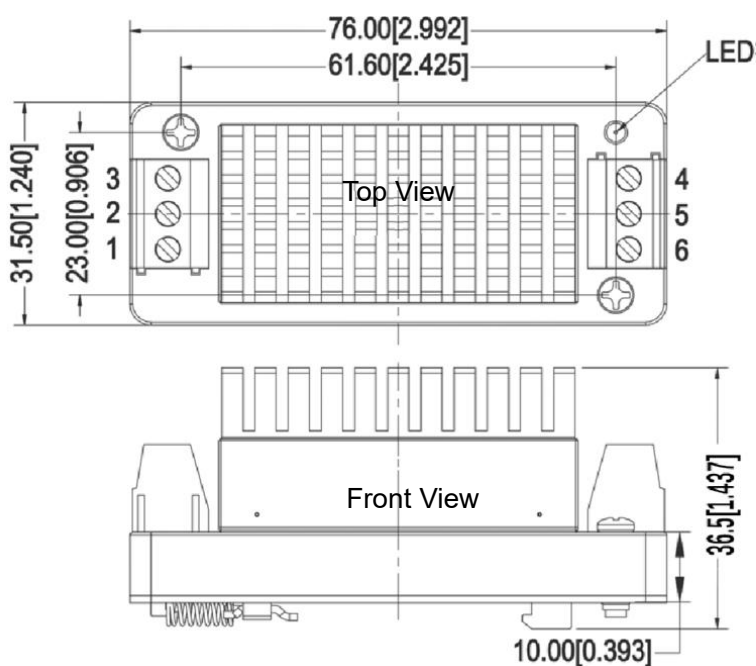

Note:
 Unit: mm[inch]
 General tolerance: $\pm 1.0[\pm 0.04]$

Terminal No.	1	2	3	4	5	6
FD50-110SXXB3C3	+Vin	-Vin	Ctrl	Trim	-Vout	+Vout

Other Models Pin-out Function Description

Pin/Terminal No.	1	2	3	4	5	6
FD50-110SXXB3N3	+Vin	-Vin	No Pin	Trim	-Vout	+Vout

Application Notice

- 1.The products should be used according to the specifications in this datasheet, otherwise it could be permanently damaged.
2. The product performance in this datasheet cannot be guaranteed if it works at a lower load than the minimum load defined.
3. The product performance in this datasheet cannot be guaranteed if it works at over-load condition.
4. Unless otherwise specified, all values or indicators in this datasheet are tested at Ta=25℃ , humidity<75%RH, nominal input voltage and rated load (pure resistance load).
5. All values or indicators in this datasheet had been tested based on Aipupower test specifications.
- 6.Specifications apply to standard models only; non-standard products may vary. Contact our technical team for details.
7. Aipupower can provide customization service.

Guangzhou Aipu Electron Technology Co., Ltd

Address: Building 4, HEDY Park, No.63, Punan Road, Huangpu Dist, Guangzhou, China.
 Tel: 86-20-84206763 Fax: 86-20-84206762 HOTLINE: 400-889-8821
 E-mail: sales@aipu-elec.com Website: <https://www.aipupower.com>